

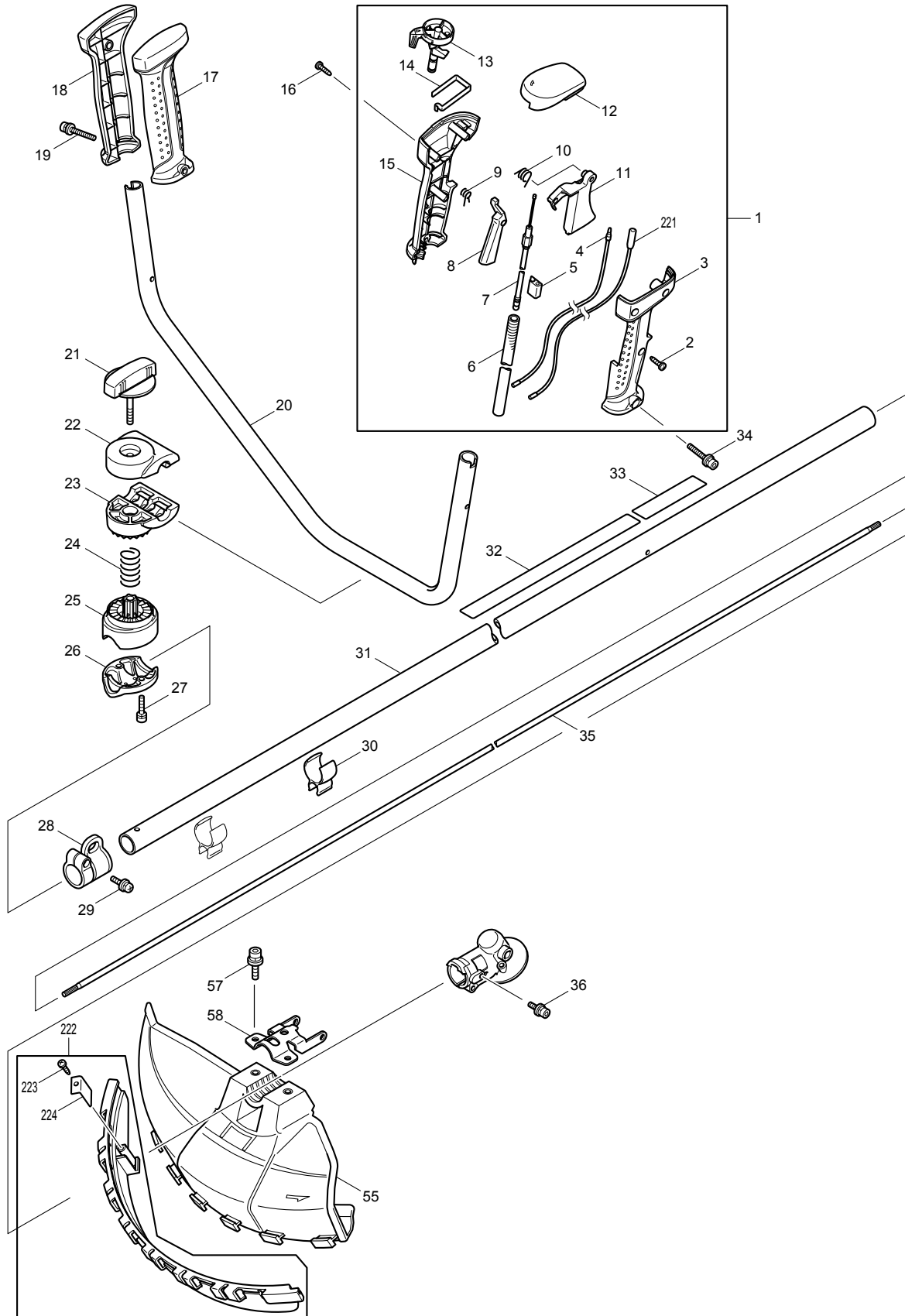

EM2650UH



Products with multiple versions are listed in subsiding order with the newest version on top not indented.

Section	Fig. No.	Part No.	Description	EM2650UH	Tech Bulletin	Notes
1	1	125775-1	CONTROL LEVER ASSEMBLY	1		
1	2	266326-2	TAPPING SCREW 4X18	3		
1	3	188656-0	LEVER CASE SET	1		
1	4	638705-8	LEAD UNIT	1		
1	5	451081-1	CABLE HOLDER	1		
1	6	452005-0	CORRUGATE TUBE	1		
1	7	168570-6	CONTROL CABLE	1		
1	8	451083-7	LOCK OFF LEVER	1		
1	9	233541-3	TORSION SPRING 7	1		
1	10	233540-5	TORSION SPRING 11	1		
1	11	451084-5	THROTTLE LEVER	1		
1	12	451085-3	SWITCH COVER	1		
1	13	451082-9	SWITCH LEVER	1		
1	14	232251-9	LEAF SPRING	1		
1	15	188656-0	LEVER CASE SET	1		
1	16	266326-2	TAPPING SCREW 4X18	1		
1	17	188659-4	GRIP SET	1		
1	18	188659-4	GRIP SET	1		
1	19	911256-9	PAN HEAD SCREW M5X35	1		
1	20	331862-8	HANDLE 19	1		
1	21	168796-0	KNOB 57	1		
1	21	168524-3	KNOB 57	1		
1	22	318429-9	HANDLE CLAMP	1		
1	23	318428-1	HANDLE HOLDER	1		
1	24	233202-5	COMPRESSION SPRING 20	1		
1	25	318427-3	PIPE HOLDER	1		
1	26	318426-5	PIPE CLAMP	1		
1	27	922241-7	HEX. SOCKET HEAD BOLT M5X25	2		
1	28	195143-2	HANGER SET	1		
1	29	911233-1	PAN HEAD SCREW M5X20	1		
1	30	451526-9	WIRE CLAMP	2		
1	31	140431-2	SHAFT PIPE COMPLETE	1		
1	32	890280-4	CAUTION LABEL	1		
1	33	819312-8	MAKITA LOGO LABEL	1		

Products with multiple versions are listed in subsiding order with the newest version on top not indented.

Section	Fig. No.	Part No.	Description	EM2650UH	Tech Bulletin	Notes
1	33	819312-8	MAKITA LOGO LABEL	1		
1	34	911256-9	PAN HEAD SCREW M5X35	1		
1	35	324893-4	SHAFT	1		
1	36	922218-2	H.S.H.BOLT M5X14 WITH WR	2		
1	55	452260-4	PROTECTOR	1		
1	57	266575-1	HEX. HEAD BOLT M6X30	2		
1	58	346073-2	PROTECTOR CLAMP	1		
1	221	638706-6	LEAD UNIT	1		
1	222	135398-7	PROTECTOR EXTENSION ASSY	1		
1	223	266326-2	TAPPING SCREW 4X18	1		
1	224	346074-0	CUTTER	1		

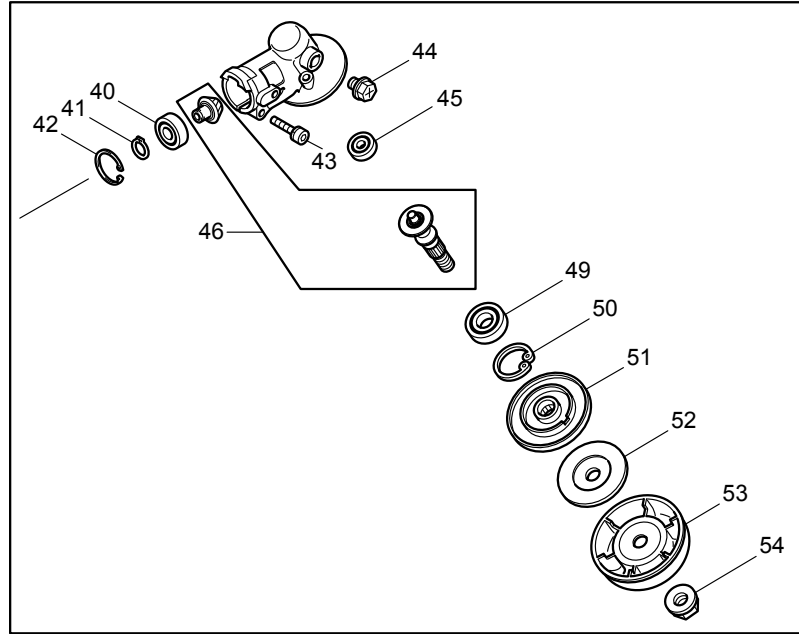

37

Prior to Nov 2012

From Nov 2012

* Spiral bevel gear and Cutter shaft complete are the components of Cutter shaft set Fig No. 46

* Spiral bevel gear and Cutter shaft complete are the components of Cutter shaft set Fig No. 46.

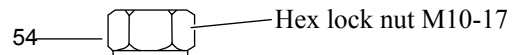
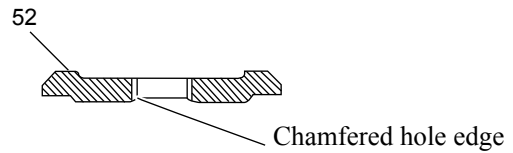
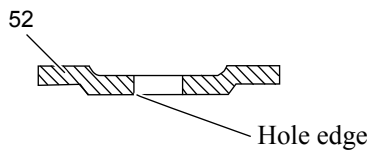
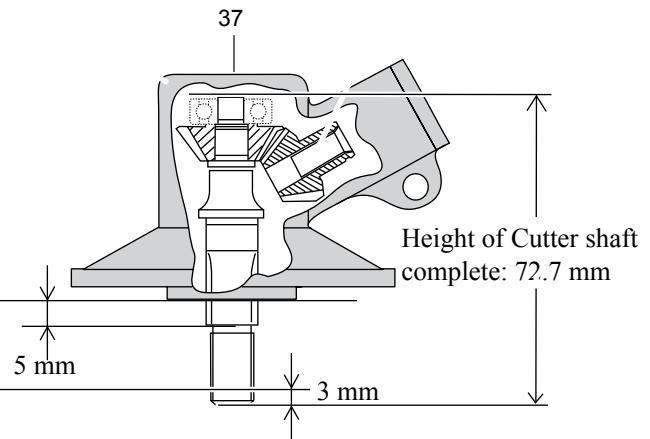
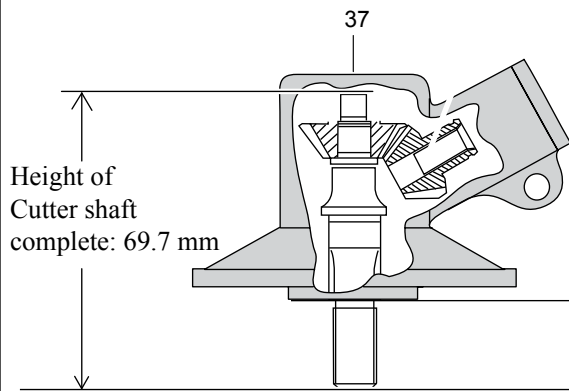

Products with multiple versions are listed in subsiding order with the newest version on top not indented.

Section	Fig. No.	Part No.	Description	EM2650UH	Tech Bulletin	Notes
2	37	126265-7	GEAR CASE ASS'Y, EM2650UH	1		
2	37	125556-3	GEAR CASE ASSEMBLY	1		
2	40	210049-4	BALL BEARING 609ZZ	1		
2	41	961005-4	RETAINING RING S-9	1		
2	42	962103-7	RETAINING RING R-24	1		
2	43	922241-7	HEX. SOCKET HEAD BOLT M5X25	1		
2	44	265590-2	+HEX.BOLT M8X10 WITH R	1		
2	46	187547-2	CUTTER SHAFT SET	1		
2	46	188902-1	CUTTER SHAFT SET	1		
2	49	210115-7	BALL BEARING 6001LLU	1		
2	50	962106-1	RETAINING RING R-28	1		
2	51	331861-0	RECEIVE WASHER	1		
2	52	346660-7	CLAMP WASHER	1		
2	52	346084-7	CLAMP WASHER	1		
2	53	168526-9	CUP	1		
2	54	264088-6	HEX. LOCK NUT M10-17	1		
2	54	264025-0	HEX. NUT M10-17	1		

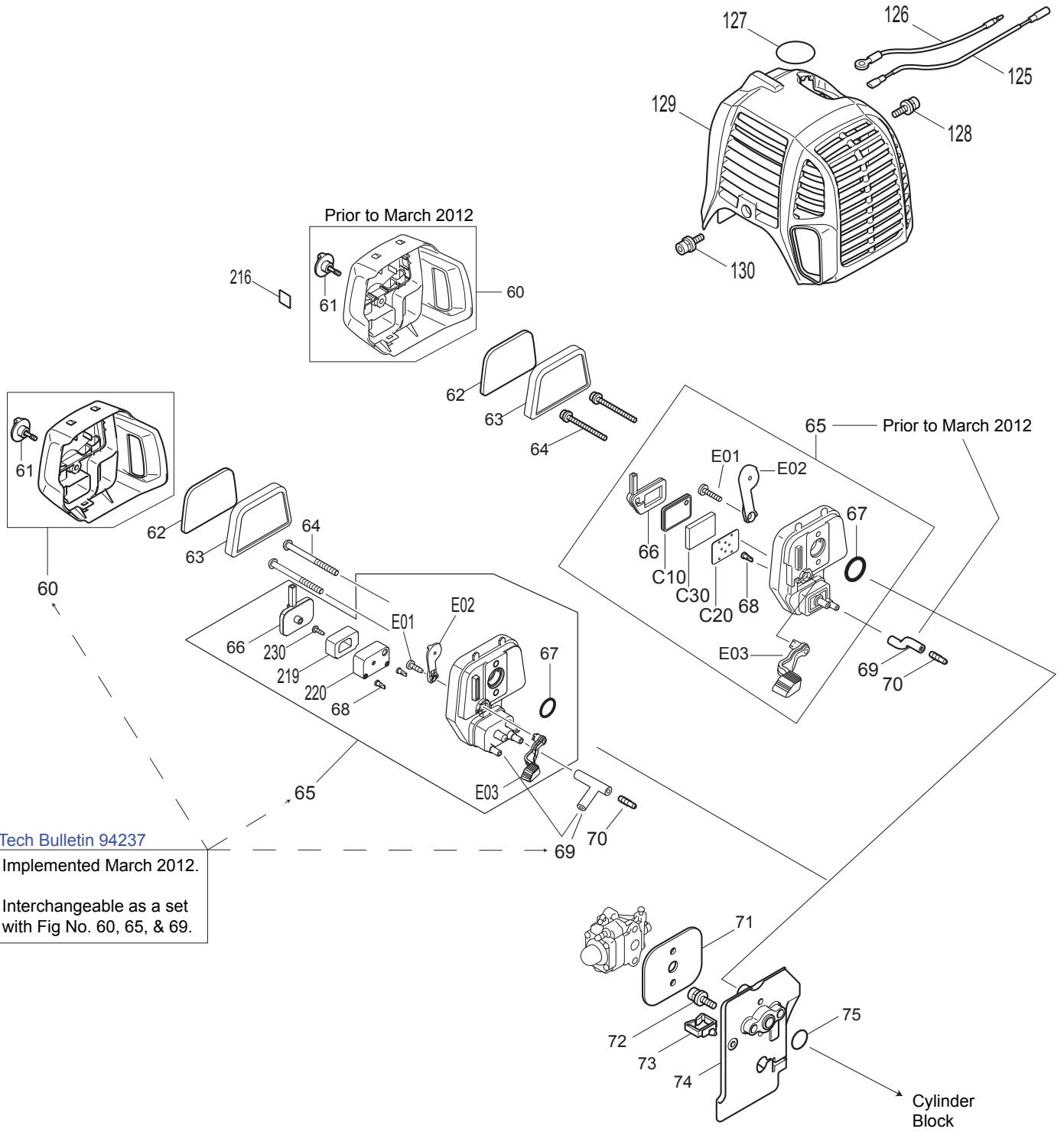

Products with multiple versions are listed in subsiding order with the newest version on top not indented.

Section	Fig. No.	Part No.	Description	EM2650UH	Tech Bulletin	Notes
3	60	126202-1	CLEANER COVER ASS'Y, EM2650LH	1		
3	60	125746-8	CLEANER COVER ASSEMBLY	1		
3	61	265791-2	THUMB SCREW M4	1		
3	62	443171-4	AIR CLEANER ELEMENT	1		
3	63	443169-1	AIR CLEANER ELEMENT	1		
3	64	266618-9	H.S.BUTTON HEAD BOLT M5X60	2		
3	65	126198-6	CLEANER PLATE ASS'Y, EM2650LH	1		
3	65	126004-5	CLEANER PLATE ASSEMBLY	1		
3	66	162346-3	SEPARATOR PLATE	1		
3	66	162324-3	SEPARATOR PLATE	1		
3	67	213540-1	O RING 15	1		
3	68	424316-3	CHECK VALVE	1		
3	69	422099-9	PIPE	1		
3	69	422062-2	PIPE	1		
3	70	325665-0	JOINT PIPE	1		
3	71	442153-3	CARBURETOR GASKET	1		
3	72	922228-9	H.S.H.BOLT M5X18 WITH WR	2		
3	73	451825-9	CLAMP	1		
3	74	451729-5	INSULATOR	1		
3	75	213547-7	O-RING 12	1		
3	125	638707-4	LEAD UNIT	1		
3	126	638708-2	LEAD UNIT	1		
3	127	808633-3	4STROKE INDICATION LABEL	1		
3	128	922218-2	H.S.H.BOLT M5X14 WITH WR	1		
3	129	453266-5	CYLINDER COVER, EM2650LH	1		
3	129	451734-2	CYLINDER COVER	1		
3	130	922218-2	H.S.H.BOLT M5X14 WITH WR	1		
3	131	424082-2	BUFFER RUBBER	1		
3	132	922211-6	HEX. SOCKET HEAD BOLT M5X12	1		
3	133	922226-3	HEX. SOCKET HEAD BOLT M5X18	2		
3	134	318249-1	PIPE HOLDER	1		
3	135	318250-6	PIPE HOLDER	1		
3	136	424083-0	BUFFER RUBBER	1		

Products with multiple versions are listed in subsiding order with the newest version on top not indented.

Section	Fig. No.	Part No.	Description	EM2650UH	Tech Bulletin	Notes
3	219	352020-3	SEPARATOR MESH, EM2650LH	1		
3	220	453865-3	SEPARATOR CASE, EM2650LH	1		
3	228	800F73-7	INDICATION LABEL	1		
3	228	891985-9	INDICATION LABEL	1		
3	C10	162322-7	SEPARATOR STOPPER	1		
3	C20	162325-1	SEPARATOR GASKET	1		
3	C30	352013-0	SEPARATOR NET	1		
3	E01	266427-6	TAPPING SCREW 4X12	1		
3	E02	452219-1	CHOKE PLATE	1		
3	E03	452220-6	CHOKE LEVER	1		

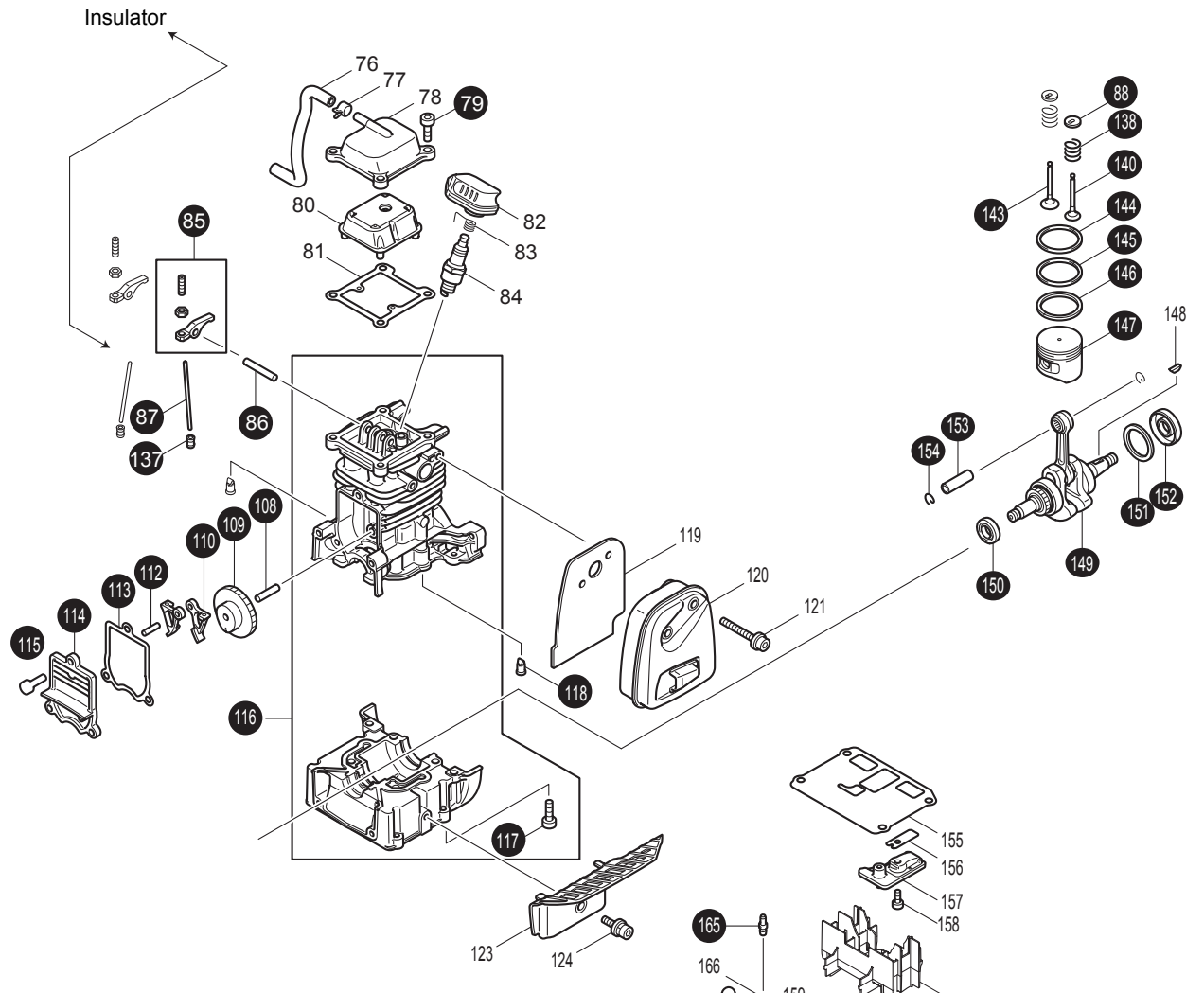

Included in Short Block Assembly Fig. No. 320.

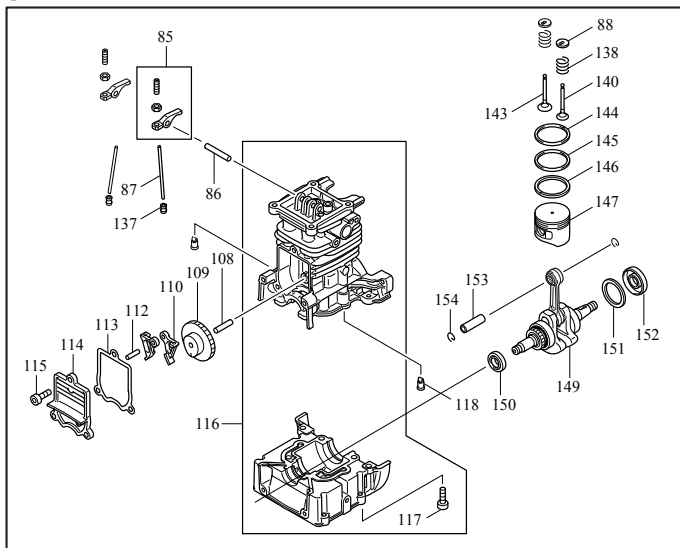

320

Products with multiple versions are listed in subsiding order with the newest version on top not indented.

Section	Fig. No.	Part No.	Description	EM2650UH	Tech Bulletin	Notes
4	76	422109-2	BREATHER PIPE	1		
4	76	422055-9	BREATHER PIPE	1		
4	77	345918-1	HOSE CLAMP	1		
4	78	318745-9	ROCKER COVER OUTER	1		
4	79	922222-1	HEX. SOCKET HEAD BOLT M5X16	4		
4	80	453860-3	ROCKER COVER INNER	1		
4	80	452795-5	ROCKER COVER INNER	1		
4	81	162304-9	ROCKER COVER GASKET	1		
4	82	424302-4	PLUG CAP	1		
4	83	324891-8	PLUG CAP SPRING	1		
4	84	168534-0	SPARK PLUG	1		
4	85	125554-7	ROCKER ARM ASSEMBLY	2		
4	86	256200-2	PIN 5	1		
4	87	256865-0	ROD 2.5	2		
4	88	325668-4	SPRING RETAINER	2		
4	108	268238-5	PIN 5	1		
4	109	125552-1	CAM GEAR ASSEMBLY	1		
4	110	313169-4	CAM LIFTER	2		
4	112	268239-3	PIN 4	1		
4	113	162274-2	CAM GEAR COVER GASKET	1		
4	114	318443-5	CAM GEAR COVER	1		
4	115	922222-1	HEX. SOCKET HEAD BOLT M5X16	3		
4	116	135478-9	CYLINDER BLOCK ASSEMBLY	1		
4	117	922222-1	HEX. SOCKET HEAD BOLT M5X16	6		
4	118	424201-0	CHECK VALVE	2		
4	119	346331-6	MUFFLER GASKET	1		
4	120	168554-4	EXHAUST MUFFLER	1		
4	121	266440-4	HEX SOCKET HEAD BOLT M5X40	2		
4	123	451731-8	MUFFLER PLATE	1		
4	124	922218-2	H.S.H.BOLT M5X14 WITH WR	1		
4	137	424200-2	SPACER	2		
4	138	234108-0	COMPRESSION SPRING 9	2		
4	140	325669-2	EXHAUST VALVE	1		

Products with multiple versions are listed in subsiding order with the newest version on top not indented.

Section	Fig. No.	Part No.	Description	EM2650UH	Tech Bulletin	Notes
4	143	325670-7	INTAKE VALVE	1		
4	144	257298-2	PISTON RING (TOP) 34	1		
4	145	257299-0	PISTON RING (SECOND) 34	1		
4	146	257300-1	PISTON RING 34	1		
4	147	318441-9	PISTON	1		
4	148	254040-2	WOODRUFF KEY 3	1		
4	149	126359-8	CRANK SHAFT ASS'Y	1		
4	149	135481-0	CRANK SHAFT ASS'Y	1		
4	150	213148-1	OIL SEAL 10	1		
4	151	267400-9	FLAT WASHER 23	1		
4	152	213147-3	OIL SEAL 12	1		
4	153	257781-9	PISTON PIN	1		
4	154	233976-8	CLIP	2		
4	155	162345-5	OIL CASE GASKET	1		
4	155	162323-5	OIL CASE GASKET	1		
4	156	346083-9	LEAD VALVE	1		
4	157	318590-2	RETAINER PLATE	1		
4	158	922112-8	HEX. SOCKET HEAD BOLT M4X10	1		
4	159	318588-9	OIL CASE	1		
4	160	922222-1	HEX. SOCKET HEAD BOLT M5X16	4		
4	161	424344-8	DAMPER	1		
4	162	346305-7	GASKET	1		
4	163	266611-3	HEX BOLT M6X8	1		
4	164	213548-5	O-RING 20	1		
4	165	325665-0	JOINT PIPE	1		
4	166	282020-8	HOSE CLAMP	1		
4	167	325666-8	OIL WEIGHT	1		
4	168	424301-6	OIL TUBE	1		
4	169	452047-4	OIL CAP	1		
4	170	424343-0	GASKET	1		
4	171	452048-2	OIL PIPE	1		
4	172	922218-2	H.S.H.BOLT M5X14 WITH WR	2		
4	235	453862-9	OIL CASE PLATE, EM2652LH	1		
4	320	135668-4	SHORT BLOCK ASSEMBLY	1		
4	320	135599-7	SHORT BLOCK ASSEMBLY	1		

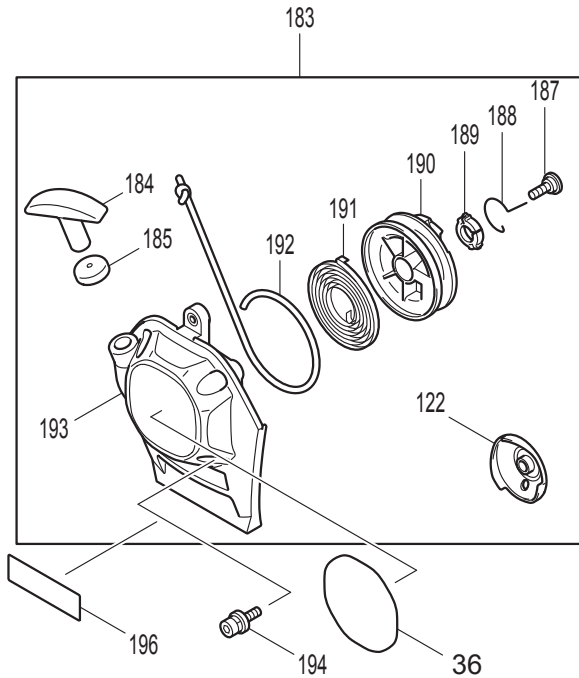
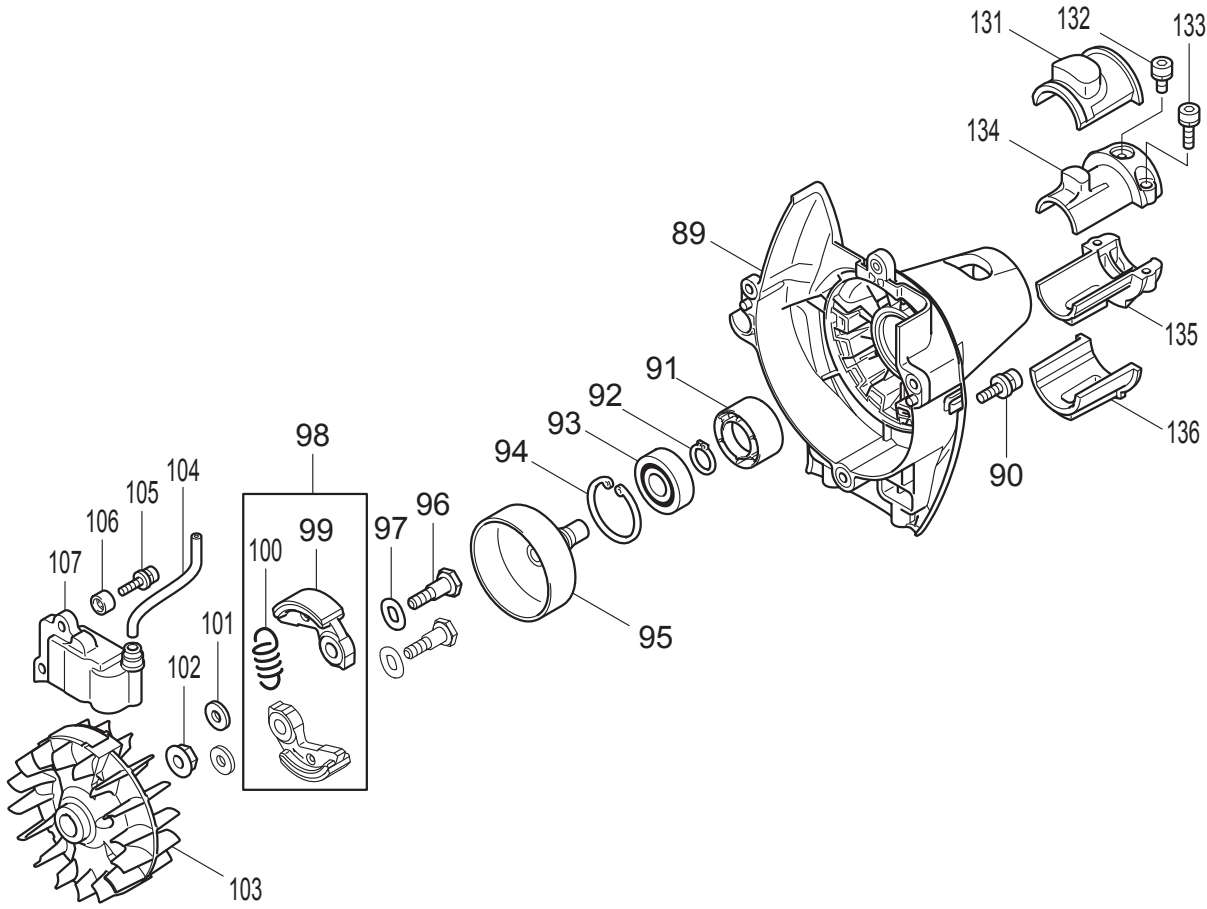

Products with multiple versions are listed in subsiding order with the newest version on top not indented.

Section	Fig. No.	Part No.	Description	EM2650UH	Tech Bulletin	Notes
5	89	451735-0	CLUTCH CASE	1		
5	90	922228-9	H.S.H.BOLT M5X18 WITH WR	3		
5	91	450569-8	SPACER	1		
5	92	961052-5	RETAINING RING S-12	1		
5	93	210111-5	BALL BEARING 6201LLU	1		
5	94	962151-6	RETAINING RING R-32	1		
5	95	168809-7	CLUTCH DRUM, EM2652LHN	1		
5	95	168609-5	CLUTCH DRUM	1		
5	96	266457-7	SHOULDER HEX. BOLT M6X25	2		
5	97	267817-6	WASHER 8	2		
5	98	126135-0	CLUTCH ASSEMBLY	1		
5	98	125518-1	CLUTCH ASSEMBLY	1		
5	99	168498-8	CLUTCH SHOE	2		
5	100	231858-8	TENSION SPRING 6	1		
5	101	267812-6	WASHER 6	2		
5	102	264039-9	FRANGE NUT	1		
5	103	318569-3	FLYWHEEL	1		
5	104	444021-6	TUBE	1		
5	105	266602-4	HEX. SOCKET HEAD BOLT M4X20	2		
5	106	452049-0	SPACER	2		
5	107	168559-4	IGNITION COIL	1		
5	122	168483-1	PULLEY	1		
5	183	195308-6	RECOIL STARTER SET	1		
5	184	424319-7	STARTER KNOB	1		
5	185	424359-5	DAMPER	1		
5	187	266585-8	TAPPING SCREW 5X12	1		
5	188	325923-4	SWING ARM	1		
5	189	451938-6	COLLAR	1		
5	190	451937-8	REEL	1		
5	191	232258-5	SPIRAL SPRING	1		
5	192	444023-2	STARTER ROPE	1		

Products with multiple versions are listed in subsiding order with the newest version on top not indented.

Section	Fig. No.	Part No.	Description	EM2650UH	Tech Bulletin	Notes
5	193	451733-4	STARTER CASE	1		
5	194	922223-9	H.S.H.BOLT M5X16 WITH WR	4		
5	196	816565-0	MAKITA LOGO LABEL	1		
5	225	819765-1	EM2650UH MODEL NO.LABEL	1		

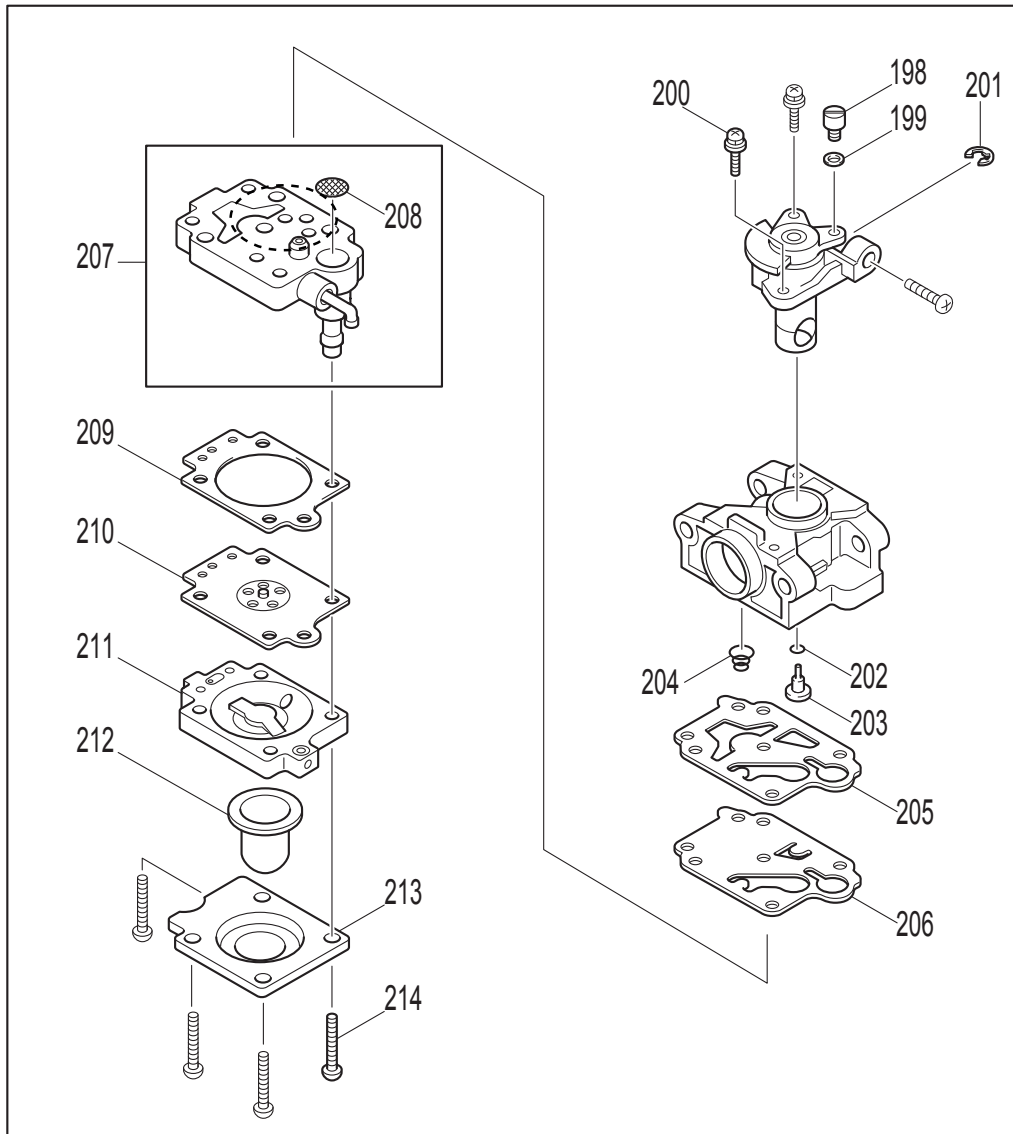
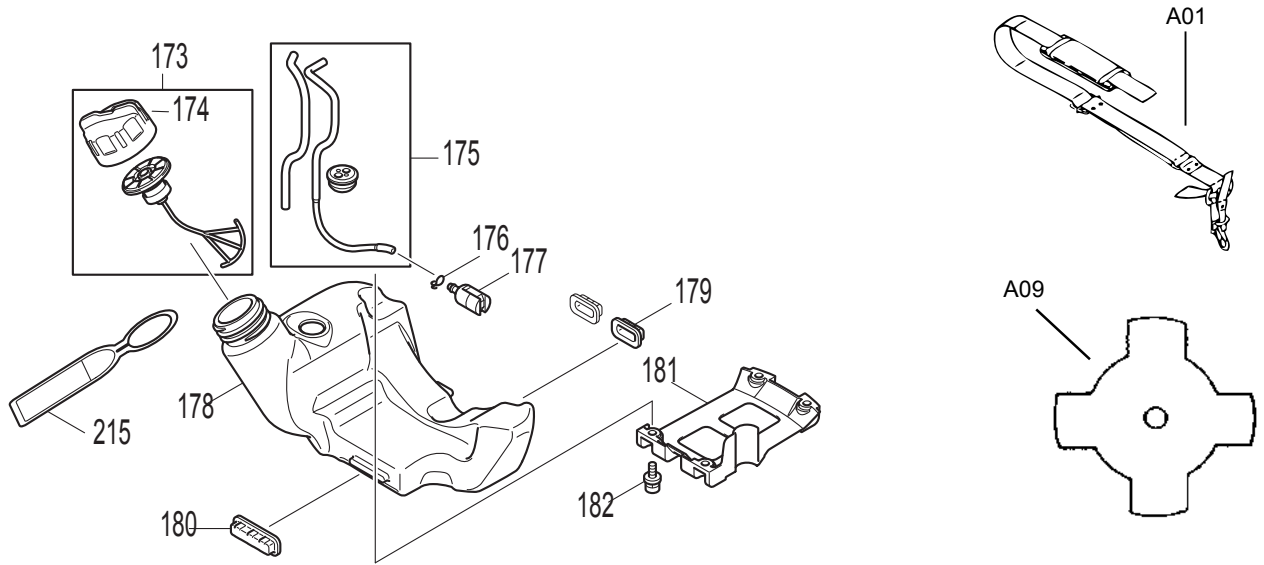

Products with multiple versions are listed in subsiding order with the newest version on top not indented.

Section	Fig. No.	Part No.	Description	EM2650UH	Tech Bulletin	Notes
6	173	125728-0	FUEL TANK CAP ASSEMBLY	1		
6	175	168755-4	TUBE CPL., EM2650LH	1		
6	176	282020-8	HOSE CLAMP	1		
6	177	163518-3	GASOLIN FILTER	1		
6	178	454010-3	FUEL TANK	1		
6	178	452249-2	FUEL TANK	1		
6	179	424080-6	BUFFER RUBBER	2		
6	180	424081-4	BUFFER RUBBER	1		
6	181	451737-6	TANK GUARD	1		
6	182	922218-2	H.S.H.BOLT M5X14 WITH WR	4		
6	197	168762-7	CARBURETOR	1		
6	197	168591-8	CARBURETOR	1		
6	198	325922-6	SWIVEL	1		
6	199	413140-9	WASHER	1		
6	200	266581-6	PAN HEAD SCREW M3X8 WITH W	2		
6	201	257964-1	STOP RING E-3	1		
6	202	213538-8	O RING 2	1		
6	203	325985-2	JET	1		
6	204	234183-6	CONICAL COMPRESSION SPRING 5-9	1		
6	205	442155-9	PUMP GASKET	1		
6	206	168575-6	PUMP DIAPHRAGM	1		
6	207	140437-0	PUMP BODY	1		
6	208	352010-6	INLET SCREEN	1		
6	209	442154-1	METERING DIAPHRAGM GASKET	1		
6	210	168620-7	METERING DIAPHRAGM	1		
6	211	140438-8	AIR PURGE BODY	1		
6	212	424314-7	PRIMER PUMP	1		
6	213	346270-0	PRIMER PUMP COVER	1		
6	214	266582-4	TAPPING SCREW 3X24	4		
6	227	810455-9	CAUTION PLATE	1		
6	A01	123143-2	BAND ASSEMBLY	1		
6	A09	B-14118	STAR BLADE 230X4TX25.4	1		